

AccessPack Hardware Guide

V1.9 25/04/2011

Contents

1	Maintenance	3
2	AccessPack Electrical Specifications.....	3
3	AccessPack Connections	3
3.1	AccessPack with Connector on PUK.....	3
3.1.1	Start-up Button Connection.....	3
3.1.2	E-Stop Connection.....	3
3.1.3	On Indicator LED or Heartbeat.....	4
3.1.4	Interface Boards.....	4
4	AccessPack Mounting Details	4
5	AccessPack Communications	5
5.1	AccessPack Communication Specifications	5
5.2	Communication Protocol	5
6	Configuring the AccessPack	7
7	AccessPack Magic Cards.....	8
7.1	Test Connections Card	8
7.2	Set Factory Defaults Card.....	8
7.3	Set Basic Mode Card	8
7.4	Set Enterprise Mode Card.....	9
8	AccessPack Operation.....	9
9	AccessPack Installation to Schneider Electric – Telemecanique Pendant	12
9.1	Installation Instructions	12
10	AccessPack Interface Boards.....	17
10.1	Crane Pendant Board.....	17
10.1.1	Electrical Specifications.....	17
10.1.2	Connections	17
10.2	Vehicle Board	18
10.2.1	Electrical specifications	18
10.2.2	Connections	18

1 Maintenance

Check the unit for mechanical damage and cracks periodically. Replace if damaged.

When the AccessPack is used in conjunction with a Liftlog logger, it is recommended that the logger unit be inspected annually and at this time logged data downloaded and saved to disk, the battery voltage checked and battery replaced if necessary. These tasks are accomplished using the Pocket FSU application running on a PDA.

2 AccessPack Electrical Specifications

Parameter	Description	Min	Typ	Max	Units
V_{in}	Supply voltage	4		8	VAC
I_{in}	Supply current	6	7	90*	mA
Start up Button Output	Current		10		mA

*only when communicating via Bluetooth

3 AccessPack Connections

3.1 AccessPack with Connector on PUK

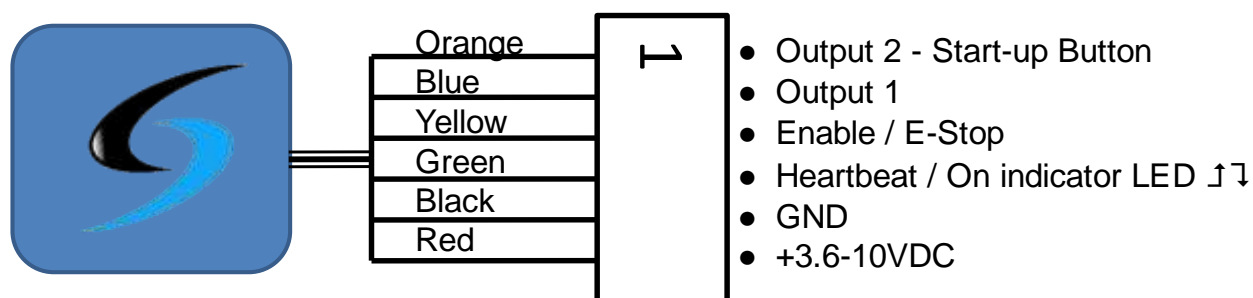

3.1.1 Start-up Button Connection

The Start-up button connection is used as a signal to provide a pulsed output to start the equipment. The start-up connection pulls low at up to 10mA

3.1.2 E-Stop Connection

The E-Stop connection is an E-Stop monitor. Simply a voltage input to show the state of the E-Stop. The signal level may be swapped by using the Pocket Field Support Unit.

5 AccessPack Communications

5.1 AccessPack Communication Specifications

Communications between the device and a host is via a Bluetooth radio link. The Bluetooth device PIN is 0000.

5.2 Communication Protocol

The host sends single character commands to the device to write or query parameters.

Each command must be followed by a carriage return <CR>(ASCII 13).

Where the command is a query command, no arguments are sent and the device will respond with a single line (except for the “?” command) the requested value in ASCII text followed by a <CR>.

Where the command is a set command, an argument may be included between the command and the <CR>. Where numbers are sent or received, they are sent as clear text; e.g. “1234”

Communication with the AccessPack using text commands is best performed while the AccessPack is connected to a Liftlog logger; otherwise the AccessPack communication is only active for a short time within a 30 second period.

<i>Command</i>	<i>R/W</i>	<i>Description</i>	<i>Example</i>
a	Read	AccessPack mode	Send:a<CR> Rcv:2
A	Write	Write AccessPack mode	Send:A2<CR>
b	Read	Read button timeout	Send:b<CR> Rcv:40
B	Write	Write button timeout	Send:A40<CR>
d	Read	Get debug level	Send:d<CR> Rcv:0
D	Write	Write debug level	Send:A0<CR>
C	Write	E Stop Edge detect mode	Send:C0<CR>EStop when estop input is asserted Send:C1<CR>EStop when estop input changes from not asserted to asserted
C	Read	E Stop Edge detect mode	Send:j<CR> Rcv:0
E	Read	Read E-Stop mode	Send:e<CR> Rcv:0
E	Write	Write E-Stop mode	Send:E0<CR> Normal E-Stop Send:E1<CR> Inverted E-Stop mode
F	Write	Mifare starting block	Send:F20<CR>
f	Read	Mifare starting block	Send:f<CR>

<i>Command</i>	<i>R/W</i>	<i>Description</i>	<i>Example</i>
			Rcv:20
G	Write	Log unauthorised cards	Send:G1<CR> log unauthorised cards Send:G0<CR> don't log them
G	Read	Log unauthorised cards	Send:g<CR> Rcv:0
H	Read	Read hardware version	Send:h<CR> Rcv:2
I	Read	Read equipment id	Send:i<CR> Rcv:hoist1
J	Write	Start Mode	Send:J0<CR> push the start button once Send:J1<CR> push the start button twice
J	Read	Start Mode	Send:j<CR> Rcv:0
I	Write	Write equipment id	Send:lhoist1<CR>
L	Read	Read logger Bluetooth id	Send:l Rcv:00:07:80:86:19:47
L	Write	Set logger Bluetooth id	Send:L00:07:80:86:19:47<CR>
M	Read	Read motion threshold	Send:m<CR> Rcv:20
M	Write	Write motion threshold	Send:M20<CR>
N	Read	Read pendant mode	Send:n<CR> Rcv:
N	Write	Write pendant mode	Send:N1<CR> Set to pendant mode Send:N0<CR> Set normal mode
O	Read	Read motion settle time	Send:o<CR> Rcv:10
O	Write	Write motion settle time	Send:O10<CR>
P	Read	Read putdown timeout	Send:p<CR> Rcv:125
P	Write	Write putdown timeout	Send:P0<CR> put down timeout disabled. Send:P255<CR> Put down timeout 25.5seconds
Q	Read	Read equipment class	Send:q Rcv:crane
Q	Write	Write equipment class	Send:Qcrane<CR>
R	Read	Read RFID scan timeout	Send:r<CR> Rcv:85
R	Write	Write RFID scan timeout	Send:R85<CR>
s	Read	Read site id	Send:s<CR>

<i>Command</i>	<i>R/W</i>	<i>Description</i>	<i>Example</i>
			Rcv:workshop
S	Write	Write site id	Send:Sworkshop<CR>
T	Read	Read motion timeout	Send:t<CR> Rcv:20
T	Write	Write motion timeout	Send:T20<CR>
U	Read	Read local log	Send:u0<CR> Rcv:last_user_name Send:u5<CR> Rcv:sixth_user_on_log
V	Read	Read firmware version number	Send:v<CR> Rcv:1.3
W	Write	Mifare End Block	Send:W160<CR>
W	Read	Mifare End Block	Send:w<CR> Rcv:160
X	Read	Read Door mode	Send:x<CR> Rcv:0
X	Write	Write Door mode	Send:X0<CR> Door mode disabled Send:X1<CR> Door mode enabled
Y	Read	Read time	Send:y<CR> Rcv:30/05/10 07:20
Y	Write	Write time	Send:Y30/05/10 07:20<CR>
Z	Read	Read local log size	Send:z<CR> Rcv:6
?	Read	Read all parameters	Send:?<CR>
*		Reset	Send:*<CR>
!		QA mode	Send:!!<CR>
.	Read	Read state of AccessPack	Send:.<CR> Rcv:E_STOPPED
@	Read	Running Minutes	Send:@<CR> Rcv:34982

6 Configuring the AccessPack

There are two ways to configure the AccessPack:

- a) Using a PDA running the Pocket FSU (Field Service Utility),
- b) Using the Setup Magic Card.

Option (a) is always available and provides access to advanced settings and configurations. For more information and instruction on the Pocket FSU application, download the latest version of the User Guide for Pocket Field Service Unit from <http://www.liftlog.com.au/literature.asp>

Option (b) is only available when the AccessPack is to be used with a Liftlog device (see section “AccessPack Magic Cards” for more information on configuring using Magic Cards).

7 AccessPack Magic Cards

A feature of the AccessPack is that it can use special cards to simplify some operations.

7.1 Test Connections Card

This card is used to check the connection and operation of the inputs to the AccessPack.

Simply swipe the “Test Connections” card. The AccessPack will rapidly flash the green light, signifying it has read a magic card. The AccessPack will then respond to the input connections changing state as follows:

- The red light will glow when E-stop / Enable is active.
- The green light will replicate the equipment heartbeat indicator.

To exit the test connections mode remove power to the AccessPack (i.e. disconnect battery or power down equipment).

7.2 Set Factory Defaults Card

The “Set Factory Defaults” card will reset the AccessPack to factory settings. These are detailed in Appendix C of the “Pocket Field Service Utility Manual. Restoring factory settings may be required when replacing a bound Liftlog unit or if you are having difficulty connecting to the AccessPack with the PocketFSU application.

WARNING: Resetting to factory defaults may erase the EquipmentID/Site/Class settings of the AccessPack. Be sure to record these before using this card.

To use the “Set Factory Defaults” card power up the AccessPack and pull the E-Stop out. If the AccessPack has not been previously setup, the red light will flash slowly, indicating that the unit is ready. Otherwise wait for the green flashing to stop. Swipe the “Set Factory Defaults” card. The AccessPack will rapidly flash the green light, signifying it has read a magic card. The AccessPack will now be programmed with the factory default settings.

7.3 Set Basic Mode Card

The “Set Basic” mode card will set the AccessPack to operate in the Basic access control mode. When in this mode the AccessPack will allow operation of the equipment when it reads any RFID card of the same type as the AccessPack cards. This mode of operation requires no AccessPack Manager license or administration.

Swipe the “Set Basic” card. The AccessPack will rapidly flash the green light, signifying it has read a magic card. The AccessPack is now in Basic Mode.

7.4 Set Enterprise Mode Card

The “Set Enterprise” mode card will set the AccessPack to operate in the default mode allowing access to individual pieces of equipment, classes of equipment, or sites to be controlled on a per user basis using the AccessPack Manager software

Swipe the “Set Enterprise” card. The AccessPack will rapidly flash the green light, signifying it has read a magic card. The AccessPack is now in Enterprise Mode.

8 AccessPack Operation

The AccessPack is used by placing specially configured AccessPack cards over the card swipe target (“swiping”). The current state of the AccessPack is indicated by two lights flashing in different ways. For more information on configuring AccessPack cards using the AccessPack Manager application, download the latest version of the AccessPack Manager User Guide from <http://www.liftlog.com.au/literature.asp>

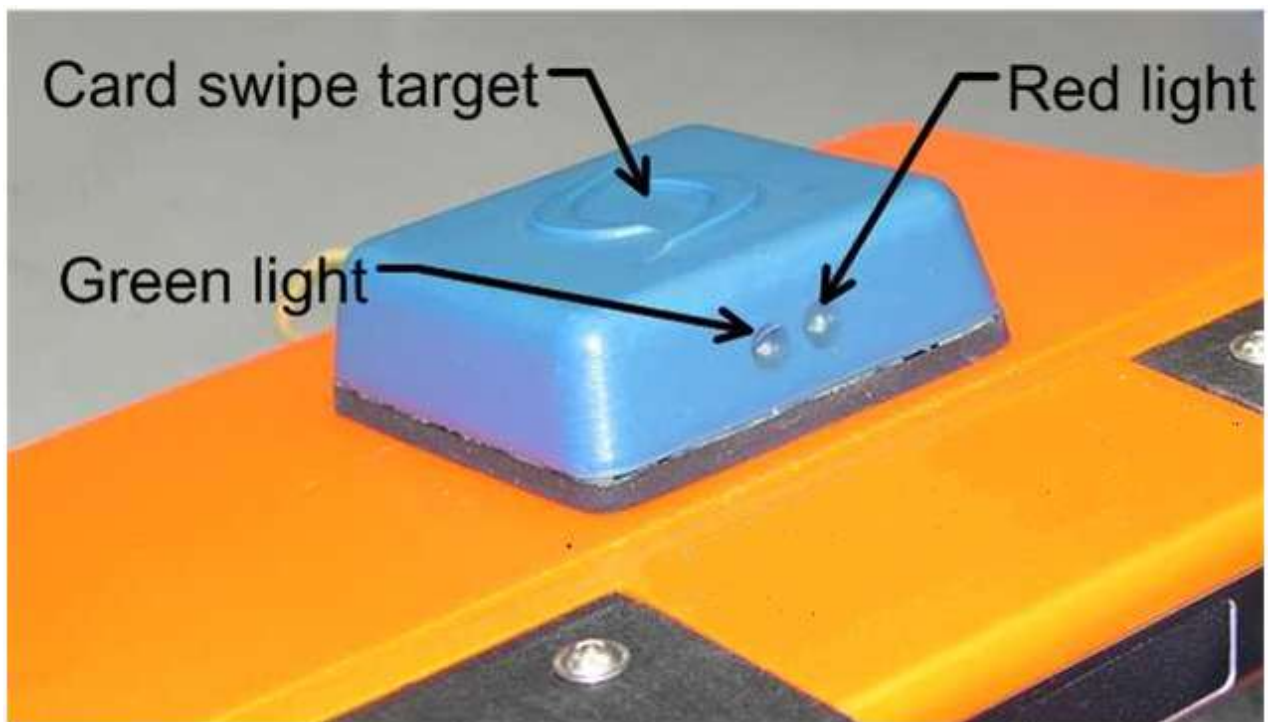



















Figure 1 The card swipe target is the outward face of the blue AccessPack and the indicator lights are used to indicate the status of the AccessPack.

To use the AccessPack follow the steps below.

- 1) With the E-stop button pressed.
- 2) Ensure the equipment is powered up.

- a. If the AccessPack power is reconnected both lights will flash briefly and then the green light will flash for several seconds while it searches for a Liftlog logger.
 - b. If the green light flashes followed by the red light flashing slowly, the AccessPack could not find a logger. The AccessPack will continue to flash the green light followed by slowly flashing the red light at regular intervals (about 30 seconds).
 - c. When the green light stops flashing with no slow red flashing, initial communication is complete.
- 3) Release the E-Stop button. AccessPack will flash the red and green lights alternately.
 - 4) Swipe a user card by moving card across target (see Figure 1). AccessPack will turn the green light on for an authorised card read or turn on the red light for an unauthorised card read.
 - 5) With an authorised card read, the equipment will be enabled by the AccessPack. The equipment will beep (if a beeper is fitted) and the AccessPack green light will flash slowly to indicate that the equipment is operable.
 - 6) If the E-Stop button is pressed the user will be logged off and the equipment made inoperable. The user will also be logged out if the equipment has an inactivity timeout or is stationary (put down function enabled).
 - 7) When the AccessPack is logging out, the red light will flash rapidly for several seconds. After being logged out, the AccessPack must once again be swiped to enable the equipment

Indicator light states for AccessPack operation

State	LED signals		Flash Rate	Notes
	Green	Red		
Power up			Quick single flash red and green together	Short flash on power up to indicate AccessPack is on
Looking for Liftlog after power on			Medium rate	
Cannot find Liftlog			Slow	Check Liftlog for powered up state
Idle – logged off				
Ready to swipe card			Alternating flashing	
Logged on			Slow	
Card Accepted			Light on 2 seconds	
Card rejected				See AccessPack administrator
About to be logged off and			Fast	

logged off (before idle state)



Red light on



Red light flashing



Red light off



Green light on



Green light flashing



Green light off

9 AccessPack Installation to Schneider Electric – Telemecanique Pendant

9.1 Installation Instructions

1. Remove front and rear covers from the pendant.
2. Remove the ON button contacts. The AccessPack will provide an ON signal to the switch board when an operator swipes on.
3. Install an additional set of NC (normally closed) contacts to the ESTOP button. The AccessPack will use the additional switch to monitor the E-STOP state.

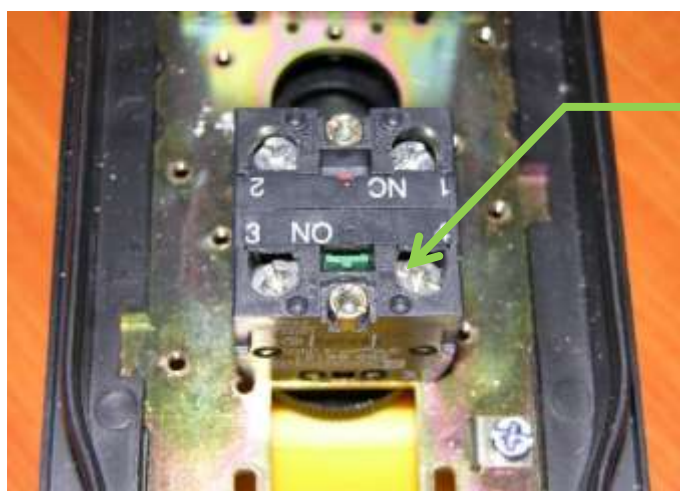

Position an additional NC set of contacts on the ESTOP button

4. Punch out the 20mm hole in the bottom of the pendant.



5. Position the drilling jig onto the bottom of the pendant (four holes locate the jig), ensure the arrow is pointing to the front of the pendant (button side).



Arrow pointing to front of pendant (button side)

6. Drill the two 3.5mm holes, deburr the holes and remove any swarf.
7. Replace the front cover of the pendant (the cover with the buttons).
8. Taking care that the gasket is correctly in place and the red and green indicator lights face the front of the pendant (button side) install the AccessPack.



Gasket correctly in position

9. Ensure the foam insulator is correctly position beneath the board and install the interface board and connect the AccessPack to the Interface Board,



10. Connect the Interface Board as shown in the Figure 2.

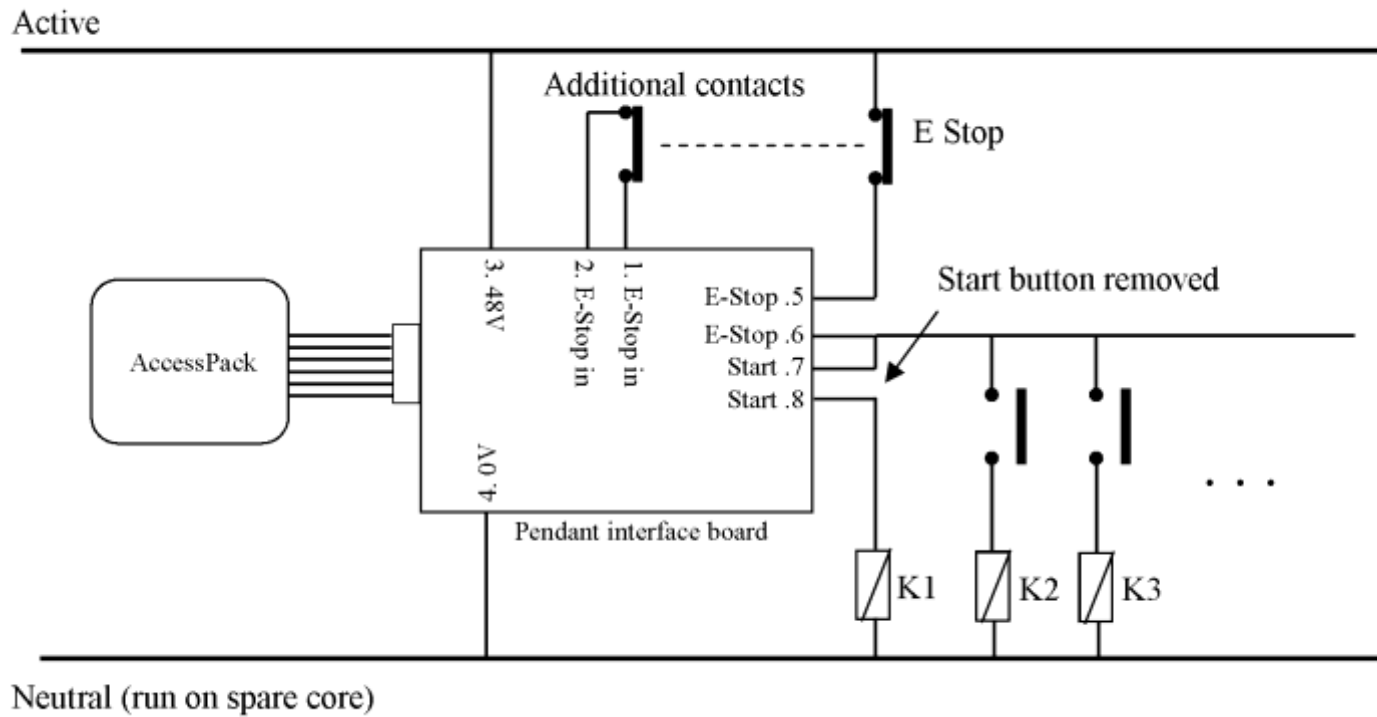
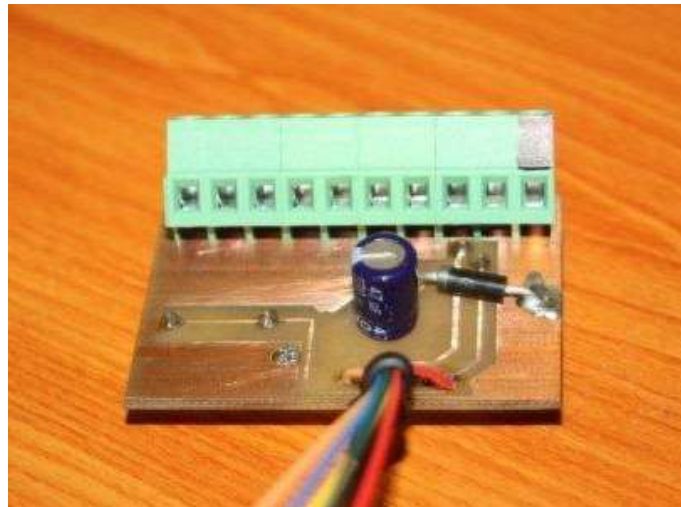

Figure 2 AccessPack Pendant Interface board connections

It may be necessary to run a new 48V AC neutral conductor from the switch panel to the pendant to provide the AccessPack Interface board with 48V AC.

The diagram below shows the location of terminal 1, shown by the black dot on the green terminal block.



11. Place a thin piece of material (for example a business card against the gasket to prevent the gasket being dislodged when assembling the cover.

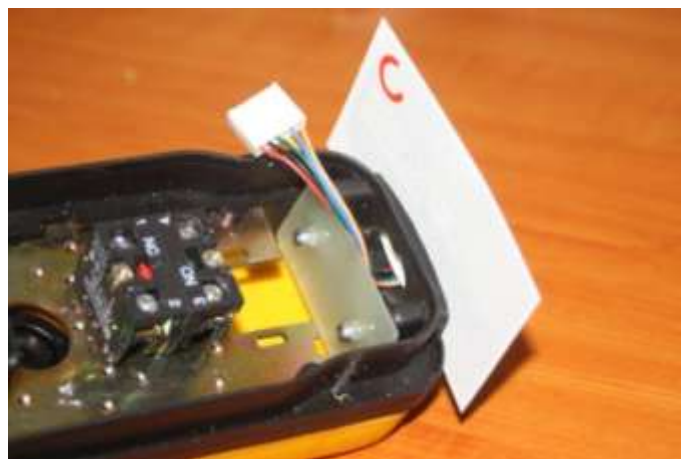

12. Tighten the Nyloc nuts to secure the AccessPack (do not over tighten).
13. Replace pendant rear cover, secure fasteners and remove the material between the cover and the gasket.



10 AccessPack Interface Boards

10.1 Crane Pendant Board

10.1.1 Electrical Specifications

Parameter	Description	Min	Typ	Max	Units
V _{in}	Supply voltage	18		55	VAC
Relay Output 1	Current			500	mA
Relay Output 1	Voltage			60	VAC
Relay Output 1	Power			10	W
Relay Output 2	Current			500	mA
Relay Output 2	Voltage			60	VAC
Relay Output 2	Power			10	W

10.1.2 Connections

The diagram below shows the location of terminal 1, shown by the black dot on the green terminal block.



Terminal Number	Name	Description
1	E-Stop Monitor Switch Terminal	Connects to second NC contact on E-Stop Button
2	E-Stop Monitor Switch Terminal	
3	48VAC Input	Power
4	48VAC Input	
5	E-Stop Output	Connects in series with E-Stop switch to deactivate crane
6	E-Stop Output	
7	Start Output Terminal	Replaces start switch so AccessPack can pulse a start signal to activate crane
8	Start Output Terminal	
9	Horn Output Terminal	Connect in parallel to the start button to sound horn when crane starts
10	Horn Output Terminal	

10.2 Vehicle Board

10.2.1 Electrical specifications

Parameter	Description	Min	Typ	Max	Units
V _{in}	Supply voltage	8		14	VDC
Relay Output (NO)	Current			10	A
Relay Output (NO)	Voltage			14	VDC
Relay Output (NC)	Current			10	A

10.2.2 Connections

The diagram below shows the location of terminal 1, shown by the white sleeve on the black cable.

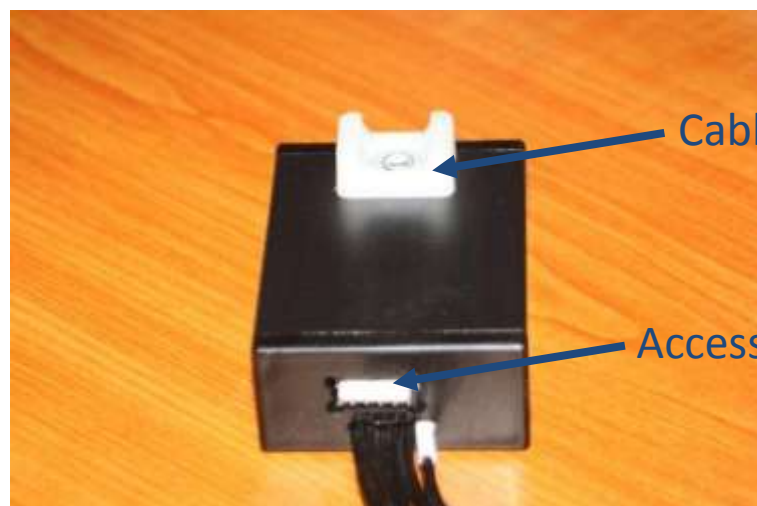

<i>Cable Number</i>	<i>Label</i>	<i>Description</i>
1 (has white sleeve)	-	Ground connection
2	+	Power connection 8 to 14V
3	Enable	
4	N/C	Relay Output Terminal Normally Closed
5	Com	Relay Output Terminal Common
6	N/O	Relay Output Terminal Normally Open

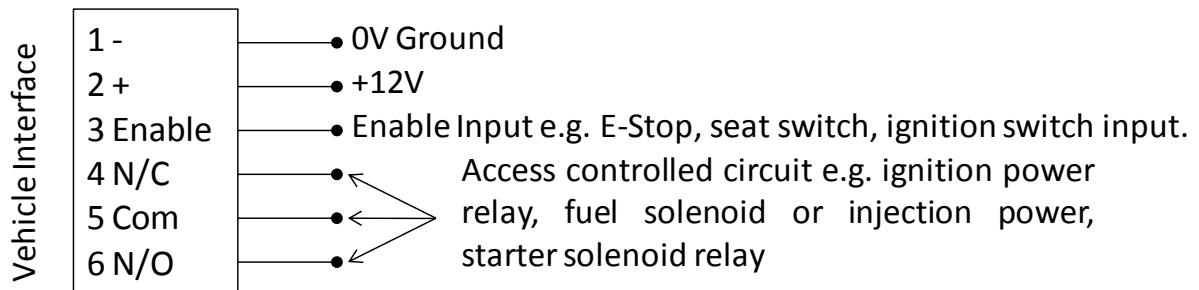

Figure 3 Example schematic of connections to Vehicle Interface Board

The enable connection is used to provide a signal to the AccessPack to commence looking for an access card.